

WESTCODE SEMICONDUCTORS

Technical
Publication
TN260C
Issue 1
November 1980

Convertor Grade Capsule Thyristor Type N260C

510 amperes average: up to 3600 volts V_{RRM}

Ratings (Maximum values at 125°C Tj unless stated otherwise)

RATING	CONDITIONS	SYMBOL	
Average on-state current	Half sine wave $\left\{ \begin{array}{l} 55^{\circ}\text{C heatsink temperature} \\ \text{(double side cooled)} \\ 85^{\circ}\text{C heatsink temperature} \\ \text{(single side cooled)} \end{array} \right.$	$I_{T(AV)}$	510A 220A
R.M.S. on-state current	25°C heatsink temperature, double side cooled	$I_T (RMS)$	1000A
Continuous on-state current	25°C heatsink temperature, double side cooled	I_T	880A
Peak one-cycle surge (non-repetitive) on state current	8.3ms duration $\left\{ \begin{array}{l} 60\% V_{RRM} \text{ re-applied} \\ V_R \leq 10 \text{ volts} \end{array} \right.$	$I_{TSM} (1)$ $I_{TSM} (2)$	6042A 6646A
Maximum permissible surge energy	With 60% V_{RRM} re-applied $\left\{ \begin{array}{l} 8.3\text{ms duration} \\ 3\text{ms duration} \end{array} \right.$	$I^2 t$	190120A ² s 145000A ² s
Peak forward gate current	Anode positive with respect to cathode	I_{FGM}	20A
Peak forward gate voltage	Anode positive with respect to cathode	V_{FGM}	32V
Peak reverse gate voltage		V_{RGM}	5V
Average gate power		P_G	2W
Peak gate power	100μs. pulse width	P_{GM}	120W
Rate of rise of off-state voltage	To 80% V_{DRM} gate open-circuit	dv/dt	* 200V/μs
Rate of rise of on-state current (repetitive)	$\left\{ \begin{array}{l} \text{Gate drive 20 volts, 20 ohms with } t_r \leq 1\mu\text{s.} \\ \text{Anode voltage } > 80\% V_{DRM} \end{array} \right.$	$di/dt (1)$	200A/μs
Rate of rise of on-state current (non-repetitive)		$di/dt (2)$	400A/μs
Operating temperature range		T_{hs}	-30 + 125°C
Storage temperature range		T_{stg}	-40 + 150°C

Characteristics (Maximum values at 125°C Tj unless stated otherwise)

CHARACTERISTIC	CONDITIONS	SYMBOL	
Peak on-state voltage	At 1100 A, I_{TM}	V_{TM}	2.73V
Forward conduction threshold voltage		V_O	1.21V
Forward conduction slope resistance		r	1.36mΩ
Repetitive peak off-state current	At V_{DRM}	I_{DRM}	60mA
Repetitive peak reverse current	At V_{RRM}	I_{RRM}	60mA
Maximum gate current required to fire all devices	At 25°C	I_{GT}	300mA
Maximum gate voltage required to fire all devices	At 25°C	V_{GT}	3V
Maximum gate voltage which will not trigger any device		V_{GD}	0.25V
Maximum holding current		I_H	1A
Thermal resistance, junction to heatsink, for a device with a maximum forward volt drop characteristic	Double side cooled Single side cooled	$R_{th(j-hs)}$	0.047°C/W 0.094°C/W

VOLTAGE CODE		H02	H04	H08	H12	H16	H20	H24	H28	H32	H36
Repetitive peak voltages	$V_{RRM} V_{DRM}$	200	400	800	1200	1600	2000	2400	2800	3200	3600
Non-repetitive peak off-state voltage	V_{DSM}	200	400	800	1200	1600	2000	2400	2800	3200	3600
Non-repetitive peak reverse blocking voltage	V_{RSM}	300	500	900	1300	1700	2100	2500	2900	3300	3700

Note: Intermediate Voltage Codes H06, 10, 14, 18, 22, 26, 30 and 34 are also available

Ordering Information (Please quote device code as explained below – 8 digits)

N 2 6 0 C	● ● ●	Typical code: N260CH24 = 2400 V_{RRM} 2400 V_{DRM} , 200 V/μs. dv/dt to 80% V_{DRM}
	Voltage code (see ratings)	

* Other values of dv/dt may be available.

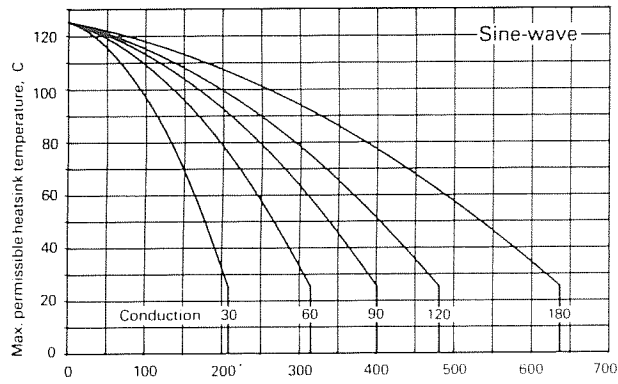

Figure 1 Dissipation and heatsink temperature v. current (Double side cooled)

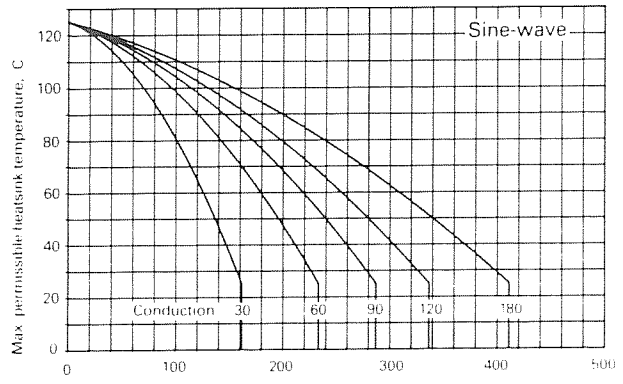

Figure 2 Dissipation and heatsink temperature v. current (Single side cooled)

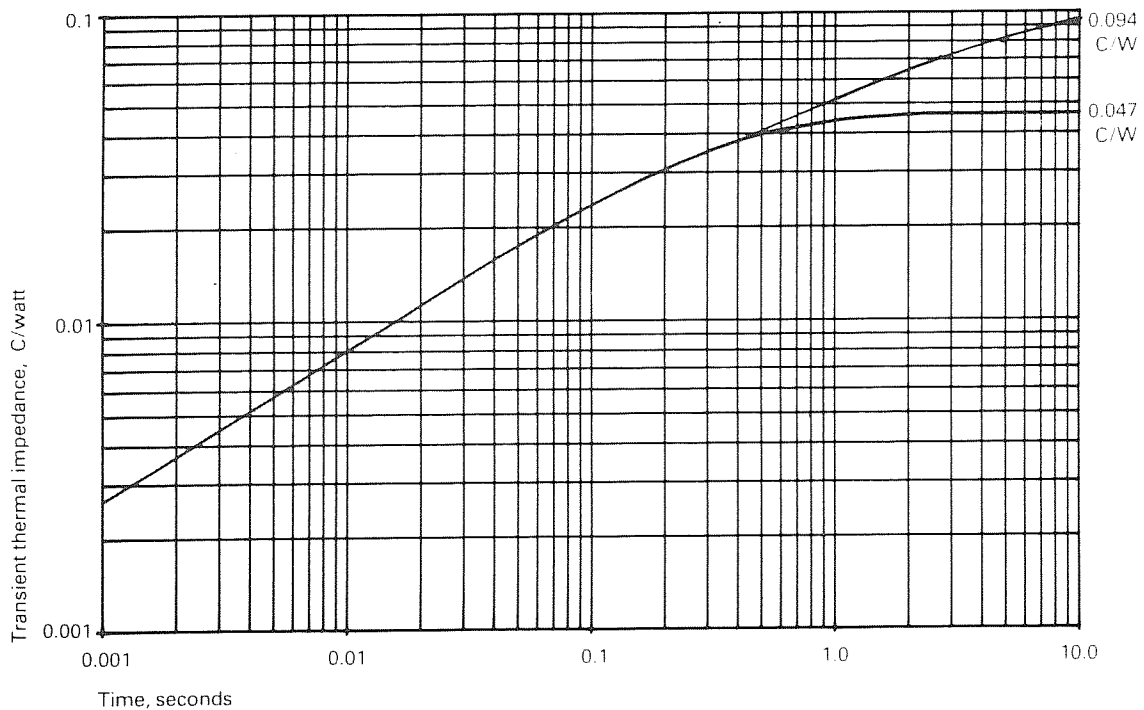
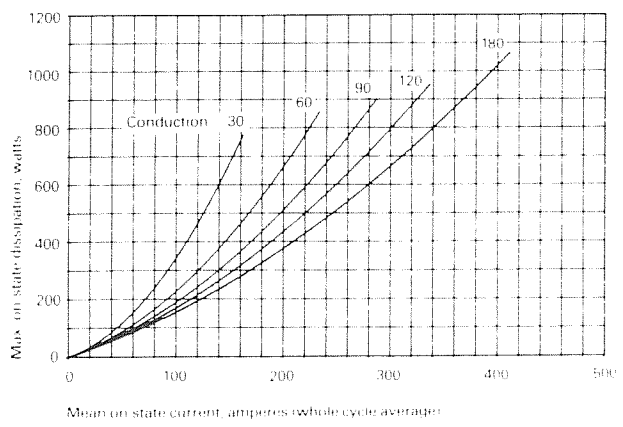
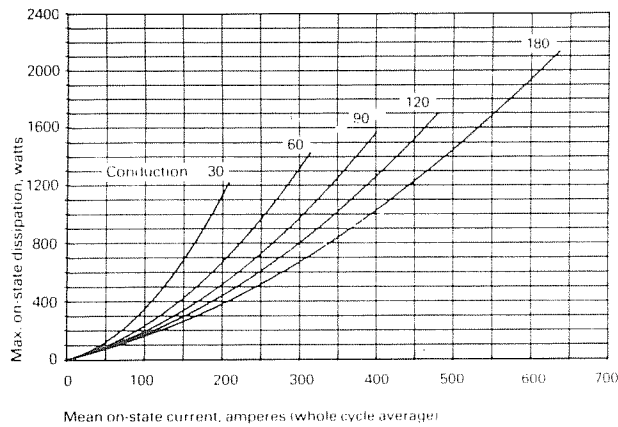

Figure 3 Junction to heatsink thermal impedance

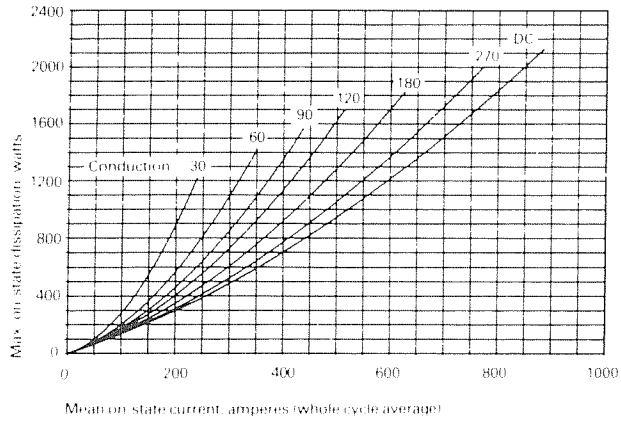
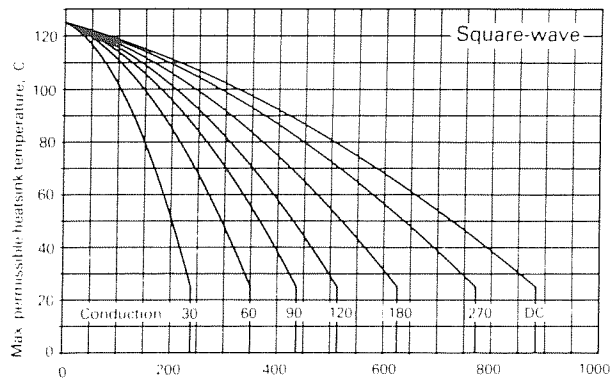

Figure 4 Dissipation and heatsink temperature v. current (Double side cooled)

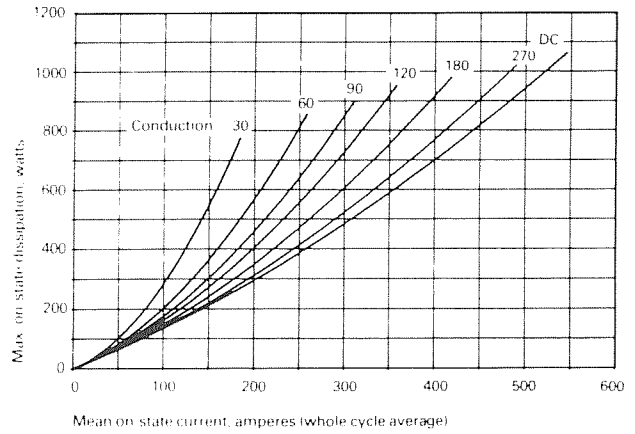
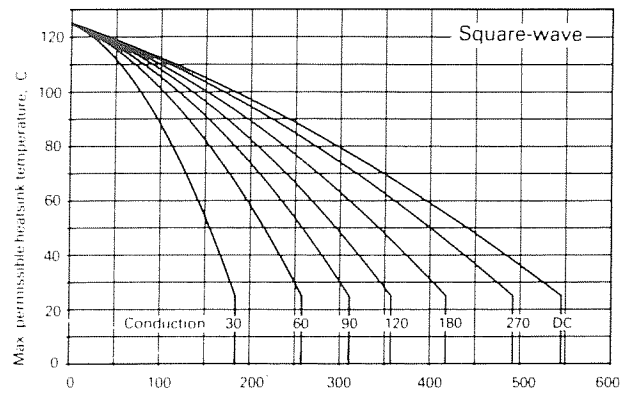

Figure 5 Dissipation and heatsink temperature v. current (Single side cooled)

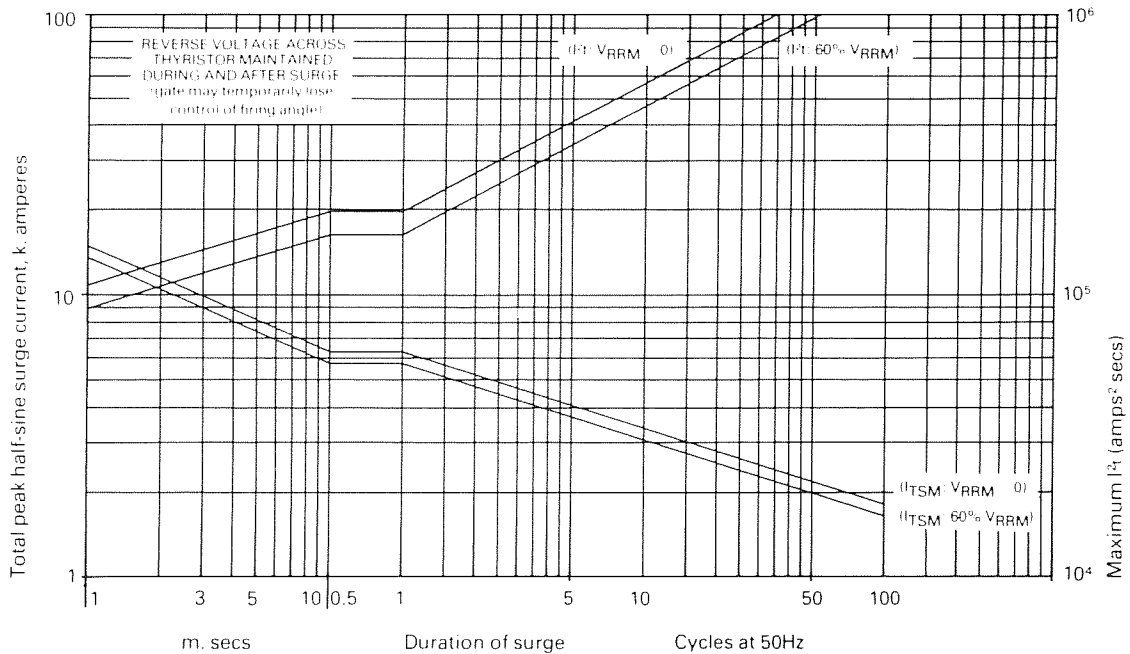

Figure 6 Max. non-repetitive surge current at initial junction temperature 125°C.
Note: This rating must not be interpreted as an intermittent rating

TN260C

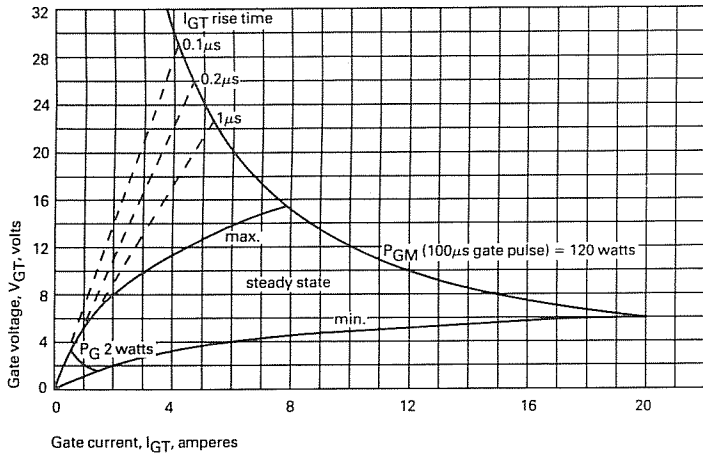

Figure 7 Gate characteristic at 25°C junction temperature

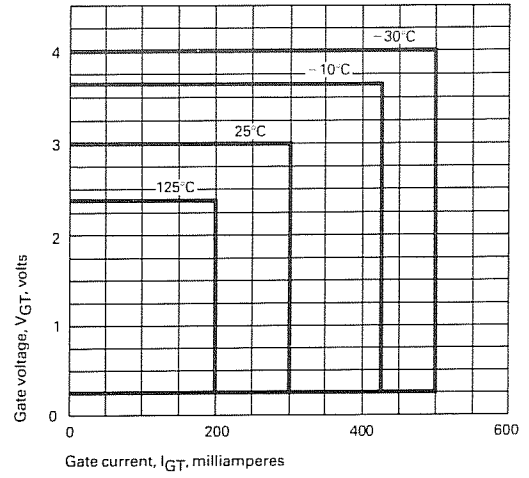

Figure 8 Gate triggering characteristics
Trigger points of all thyristors lie within the areas shown

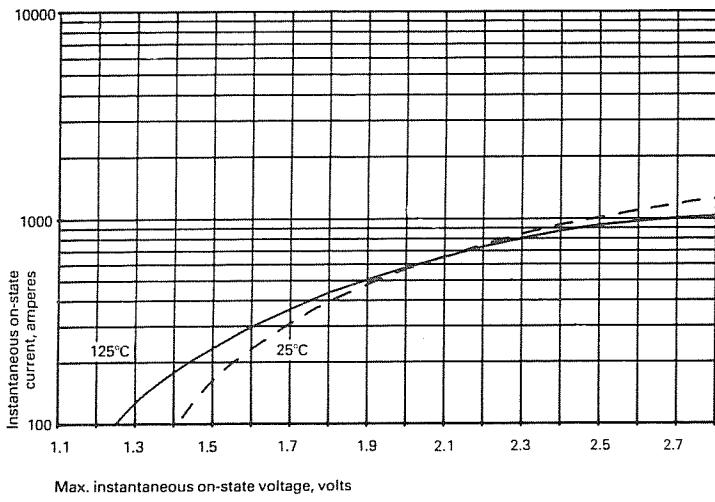
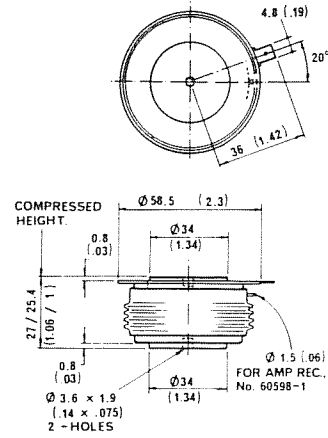

Figure 9 Limit on-state current at 125°C



TO-200AC
dimensions in mm (inches)
Mounting force: 1000-2000Kg
Weight: 340 grams

In the interest of product improvement, Westcode reserves the right to change specifications at any time without notice.

WESTCODE SEMICONDUCTORS

0-02 Fair Lawn Avenue, Fair Lawn, New Jersey 07410
Telephone: (201) 791-3020 • Telex: 130389

HAWKER SIDDELEY
Westinghouse Brake and Signal Co. Ltd.

